



3.3V CMOS 16-BIT EDGE TRIGGERED D-TYPE FLIP- FLOP WITH 3-STATE OUTPUTS, 5 VOLT TOLERANT I/O, BUS-HOLD

IDT74LVCH162374A

FEATURES:

- Typical $t_{sk(o)}$ (Output Skew) < 250ps
- ESD > 2000V per MIL-STD-883, Method 3015; > 200V using machine model (C = 200pF, R = 0)
- $V_{cc} = 3.3V \pm 0.3V$, Normal Range
- $V_{cc} = 2.7V$ to $3.6V$, Extended Range
- CMOS power levels (0.4 μ W typ. static)
- All inputs, outputs, and I/O are 5V tolerant
- Available in SSOP and TSSOP packages

DRIVE FEATURES:

- Balanced Output Drivers: $\pm 12mA$
- Low switching noise

APPLICATIONS:

- 5V and 3.3V mixed voltage systems
- Data communication and telecommunication systems

DESCRIPTION:

The LVCH162374A 16-bit edge-triggered D-type flip-flop is built using advanced dual metal CMOS technology. This high-speed, low-power register is ideal for use as a buffer register for data synchronization and storage. The output enable (\overline{OE}) and clock (CLK) controls are organized to operate each device as two 8-bit registers or one 16-bit register with common clock. Flow-through organization of signal pins simplifies layout. All inputs are designed with hysteresis for improved noise margin.

All pins of the LVCH162374A can be driven from either 3.3V or 5V devices. This feature allows the use of this device as a translator in a mixed 3.3V/5V supply system.

The LVCH162374A has series resistors in the device output structure which will significantly reduce line noise when used with light loads. This driver has been developed to drive $\pm 12mA$ at the designated thresholds.

The LVCH162374A has "bus-hold" which retains the inputs' last state whenever the input goes to a high impedance. This prevents floating inputs and eliminates the need for pull-up/down resistors.

FUNCTIONAL BLOCK DIAGRAM

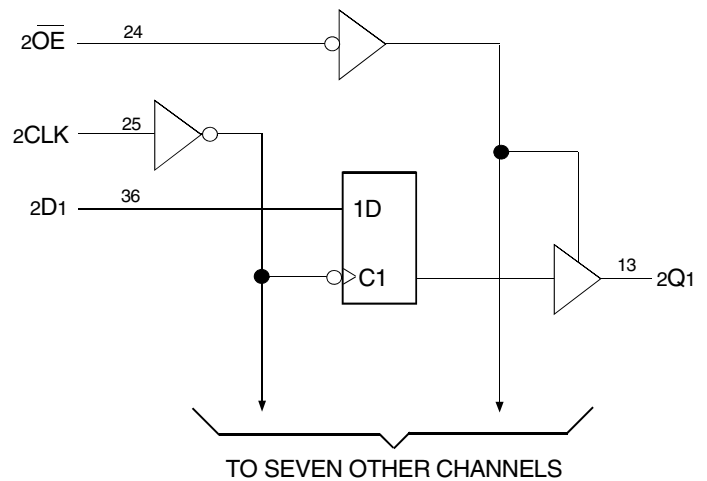
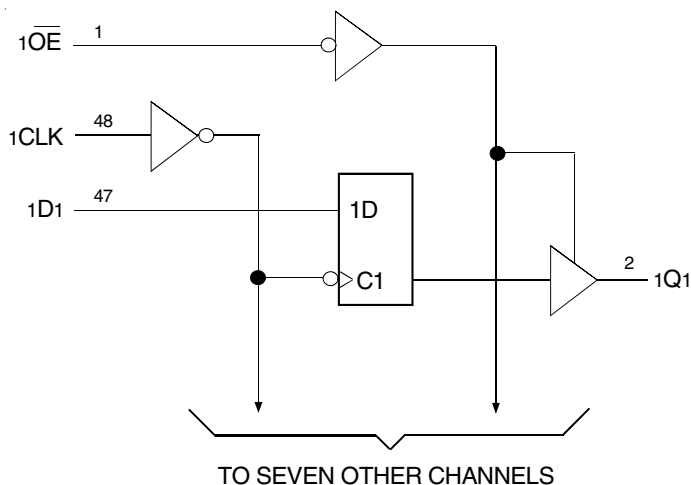

PIN CONFIGURATION

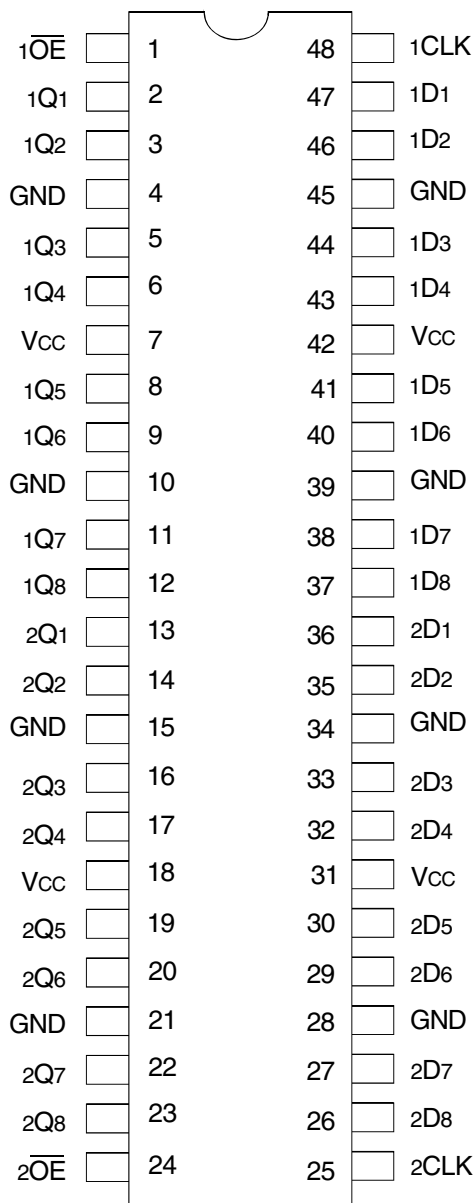

SSOP/ TSSOP
TOP VIEW

ABSOLUTE MAXIMUM RATINGS⁽¹⁾

Symbol	Description	Max	Unit
VTERM	Terminal Voltage with Respect to GND	-0.5 to +6.5	V
TSTG	Storage Temperature	-65 to +150	°C
I _{OUT}	DC Output Current	-50 to +50	mA
I _{IK} I _{OK}	Continuous Clamp Current, V _I < 0 or V _O < 0	-50	mA
I _{CC} I _{SS}	Continuous Current through each V _{CC} or GND	±100	mA

NOTE:

- Stresses greater than those listed under ABSOLUTE MAXIMUM RATINGS may cause permanent damage to the device. This is a stress rating only and functional operation of the device at these or any other conditions above those indicated in the operational sections of this specification is not implied. Exposure to absolute maximum rating conditions for extended periods may affect reliability.

CAPACITANCE (T_A = +25°C, F = 1.0MHz)

Symbol	Parameter ⁽¹⁾	Conditions	Typ.	Max.	Unit
C _{IN}	Input Capacitance	V _{IN} = 0V	4.5	6	pF
C _{OUT}	Output Capacitance	V _{OUT} = 0V	6.5	8	pF
C _{I/O}	I/O Port Capacitance	V _{IN} = 0V	6.5	8	pF

NOTE:

- As applicable to the device type.

PIN DESCRIPTION

Pin Names	Description
xD _x	Data Inputs ⁽¹⁾
xCLK	Clock Inputs
xQ _x	3-State Outputs
xOE	3-State Output Enable Inputs (Active LOW)

NOTE:

- These pins have "Bus-Hold". All other pins are standard inputs, outputs, or I/Os.

FUNCTION TABLE (EACH FLIP-FLOP)⁽¹⁾

Inputs			Outputs
xOE	xCLK	xD _x	xQ _x
L	↑	H	H
L	↑	L	L
L	H or L	X	Q ⁽²⁾
H	X	X	Z

NOTES:

- H = HIGH Voltage Level
X = Don't Care
L = LOW Voltage Level
Z = High-Impedance
- Output level before the indicated steady-state input conditions were established.

DC ELECTRICAL CHARACTERISTICS OVER OPERATING RANGE

Following Conditions Apply Unless Otherwise Specified:

Operating Condition: $T_A = -40^{\circ}\text{C}$ to $+85^{\circ}\text{C}$

Symbol	Parameter	Test Conditions		Min.	Typ. ⁽¹⁾	Max.	Unit
V _{IH}	Input HIGH Voltage Level	V _{CC} = 2.3V to 2.7V		1.7	—	—	V
		V _{CC} = 2.7V to 3.6V		2	—	—	
V _{IL}	Input LOW Voltage Level	V _{CC} = 2.3V to 2.7V		—	—	0.7	V
		V _{CC} = 2.7V to 3.6V		—	—	0.8	
I _{IH} I _{IL}	Input Leakage Current	V _{CC} = 3.6V	V _I = 0 to 5.5V	—	—	±5	μA
I _{OZH} I _{OZL}	High Impedance Output Current (3-State Output pins)	V _{CC} = 3.6V	V _O = 0 to 5.5V	—	—	±10	μA
I _{OFF}	Input/Output Power Off Leakage	V _{CC} = 0V, V _{IN} or V _O ≤ 5.5V		—	—	±50	μA
V _{IK}	Clamp Diode Voltage	V _{CC} = 2.3V, I _{IN} = -18mA		—	-0.7	-1.2	V
V _H	Input Hysteresis	V _{CC} = 3.3V		—	100	—	mV
I _{CC1} I _{CC2} I _{CC3}	Quiescent Power Supply Current	V _{CC} = 3.6V	V _{IN} = GND or V _{CC}	—	—	10	μA
			3.6 ≤ V _{IN} ≤ 5.5V ⁽²⁾	—	—	10	
ΔI _{CC}	Quiescent Power Supply Current Variation	One input at V _{CC} - 0.6V, other inputs at V _{CC} or GND		—	—	500	μA

NOTES:

1. Typical values are at V_{CC} = 3.3V, +25°C ambient.
2. This applies in the disabled state only.

BUS-HOLD CHARACTERISTICS

Symbol	Parameter ⁽¹⁾	Test Conditions		Min.	Typ. ⁽²⁾	Max.	Unit
I _{BHH} I _{BHL}	Bus-Hold Input Sustain Current	V _{CC} = 3V	V _I = 2V	-75	—	—	μA
			V _I = 0.8V	75	—	—	
I _{BHH} I _{BHL}	Bus-Hold Input Sustain Current	V _{CC} = 2.3V	V _I = 1.7V	—	—	—	μA
			V _I = 0.7V	—	—	—	
I _{BHHO} I _{BHLO}	Bus-Hold Input Overdrive Current	V _{CC} = 3.6V	V _I = 0 to 3.6V	—	—	±500	μA

NOTES:

1. Pins with Bus-Hold are identified in the pin description.
2. Typical values are at V_{CC} = 3.3V, +25°C ambient.

OUTPUT DRIVE CHARACTERISTICS

Symbol	Parameter	Test Conditions ⁽¹⁾		Min.	Max.	Unit
VOH	Output HIGH Voltage	VCC = 2.3V to 3.6V	IOH = - 0.1mA	VCC - 0.2	—	V
		VCC = 2.3V	IOH = - 4mA	1.9	—	
			IOH = - 6mA	1.7	—	
		VCC = 2.7V	IOH = - 4mA	2.2	—	
			IOH = - 8mA	2	—	
		VCC = 3V	IOH = - 6mA	2.4	—	
IOH = - 12mA	2		—			
VOL	Output LOW Voltage	VCC = 2.3V to 3.6V	IOL = 0.1mA	—	0.2	V
		VCC = 2.3V	IOL = 4mA	—	0.4	
			IOL = 6mA	—	0.55	
		VCC = 2.7V	IOL = 4mA	—	0.4	
			IOL = 8mA	—	0.6	
		VCC = 3V	IOL = 6mA	—	0.55	
IOL = 12mA	—		0.8			

NOTE:
1. VIH and VIL must be within the min. or max. range shown in the DC ELECTRICAL CHARACTERISTICS OVER OPERATING RANGE table for the appropriate VCC range. TA = - 40°C to + 85°C.

OPERATING CHARACTERISTICS, VCC = 3.3V ± 0.3V, TA = 25°C

Symbol	Parameter	Test Conditions	Typical	Unit
CPD	Power Dissipation Capacitance per Flip-Flop Outputs enabled	CL = 0pF, f = 10Mhz	—	pF
CPD	Power Dissipation Capacitance per Flip-Flop Outputs disabled		—	

SWITCHING CHARACTERISTICS⁽¹⁾

Symbol	Parameter	VCC = 2.7V		VCC = 3.3V ± 0.3V		Unit
		Min.	Max.	Min.	Max.	
tPLH	Propagation Delay	2	6.5	2	6.2	ns
tPHL	xCLK to xQx					
tPZH	Output Enable Time	1.5	6.3	1.5	6.1	ns
tPZL	xOE to xQx					
tPHZ	Output Disable Time	1.5	6.2	1.5	6	ns
tPLZ	xOE to xQx					
tSU	Set-up Time HIGH or LOW, xDx before xCLK	2.5	—	2.5	—	ns
tH	Hold Time HIGH or LOW, xDx after xCLK	1.5	—	1.5	—	ns
tW	xCLK Pulse Width HIGH or LOW	3	—	3	—	ns
tsk(o)	Output Skew ⁽²⁾	—	—	—	500	ps

NOTES:
1. See TEST CIRCUITS AND WAVEFORMS. TA = - 40°C to + 85°C.
2. Skew between any two outputs of the same package and switching in the same direction.

TEST CIRCUITS AND WAVEFORMS

TEST CONDITIONS

Symbol	V _{CC} ⁽¹⁾ =3.3V±0.3V	V _{CC} ⁽¹⁾ =2.7V	V _{CC} ⁽²⁾ =2.5V±0.2V	Unit
V _{LOAD}	6	6	2 x V _{CC}	V
V _{IH}	2.7	2.7	V _{CC}	V
V _T	1.5	1.5	V _{CC} / 2	V
V _{LZ}	300	300	150	mV
V _{HZ}	300	300	150	mV
C _L	50	50	30	pF

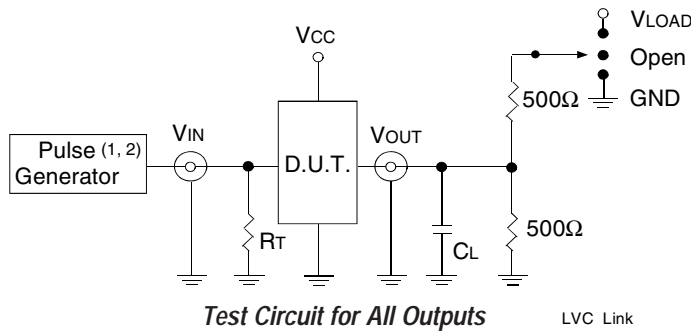

DEFINITIONS:

C_L = Load capacitance: includes jig and probe capacitance.
R_T = Termination resistance: should be equal to Z_{OUT} of the Pulse Generator.

NOTES:

1. Pulse Generator for All Pulses: Rate ≤ 10MHz; t_F ≤ 2.5ns; t_R ≤ 2.5ns.
2. Pulse Generator for All Pulses: Rate ≤ 10MHz; t_F ≤ 2ns; t_R ≤ 2ns.

SWITCH POSITION

Test	Switch
Open Drain Disable Low Enable Low	V _{LOAD}
Disable High Enable High	GND
All Other Tests	Open

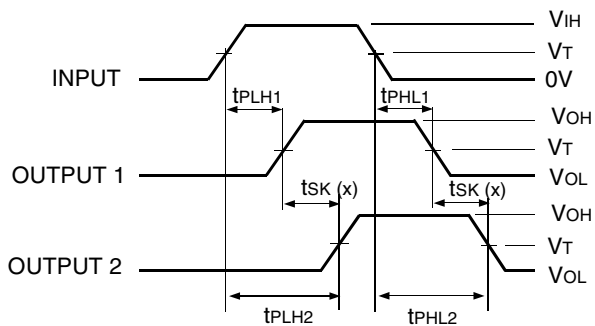

$$t_{SK}(x) = |t_{PLH2} - t_{PLH1}| \text{ or } |t_{PHL2} - t_{PHL1}|$$

NOTES:

1. For t_{SK}(o) OUTPUT1 and OUTPUT2 are any two outputs.
2. For t_{SK}(b) OUTPUT1 and OUTPUT2 are in the same bank.

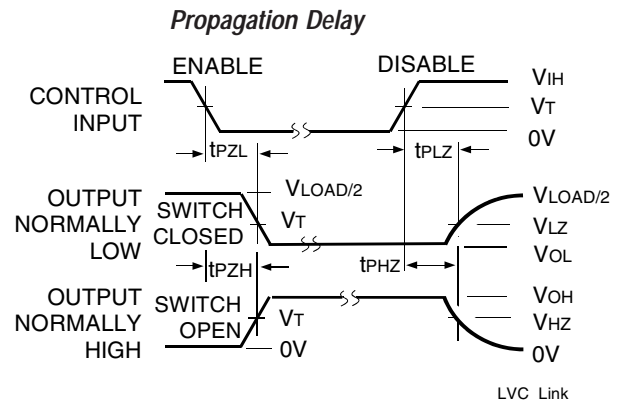
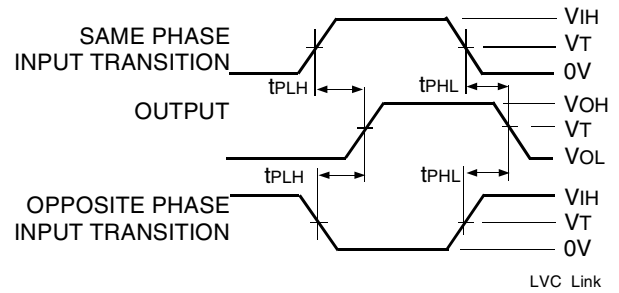

NOTE:

1. Diagram shown for input Control Enable-LOW and input Control Disable-HIGH.

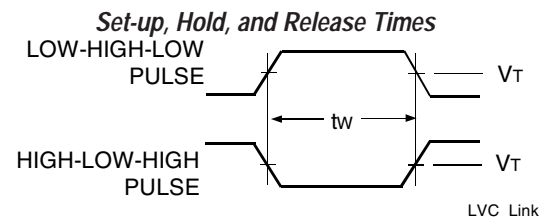
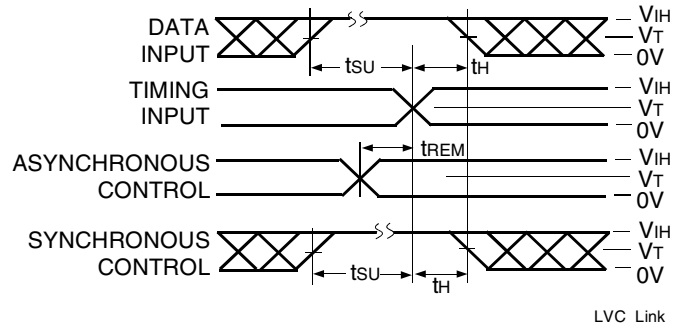

Pulse Width

ORDERING INFORMATION

